

Bushnell®



RIFLESCOPE OWNER'S GUIDE

<u>CONTENTS</u>	<u>PAGE</u>
Basic Instructions	3-6
Technical Specifications	7
BALLISTIC RETICLE DETAILS	
Drop Zone-22	8
Drop Zone-223	9
Drop Zone-308	10
BTR-1 Tactical	11
Drop Zone 6.5 Creedmoor	12
BTR-300 Blackout	13
Windhold	14
Interchangeable Turrets <i>(Model# AR741840E / AR741840EI only)</i>	15
Ballistic Reference Tables <i>(AR741840E / AR741840EI Turrets)</i>	16
Ironclad Warranty	17

Congratulations on your purchase of a Bushnell® AR Optics™ riflescope! You are now the owner of one of the most technologically advanced riflescopes in the industry. Bushnell maintains absolute product integrity and quality control throughout the entire design, production, and delivery cycle of these riflescopes.



WARNING: NEVER LOOK AT THE SUN THROUGH THE RIFLESCOPE (OR ANY OTHER OPTICAL INSTRUMENT). IT MAY PERMANENTLY DAMAGE YOUR EYES.

AR OPTICS RIFLESCOPE FEATURES

Bushnell® is constantly at the forefront of quality and value, and AR Optics™ riflescopes are designed specifically for the AR platform, delivering maximum accuracy and reliability to master every tactical scenario. There is a scope for every popular caliber, including 22 LR, .223/5.56, .308, 300 Blackout, and even 6.5 Creedmoor. Fully-Multi Coated Optics and waterproof construction offer crisp, bright images in every environment. Many models include our PCL Throw Down Power Change Lever with interchangeable short and long handles, making these scopes as customizable as the rifles they share a name with. The new lineup of AR Optics™ riflescopes from Bushnell® won't disappoint.

All AR Optics riflescope models feature:

- CLARITY - The best resolution and contrast in all lighting conditions
- WIDE RANGE OF MODELS - Multiple configurations, turret types, tube diameters and reticles to cover every situation and user preference.
- SPECIAL FEATURES- Selected models offer illuminated reticles and our PCL "Throw Down" Power Change Lever.
- HIGH LIGHT TRANSMISSION - Ultra Wide Band Coating enables optimum brightness and true color in every lighting condition.

CARING FOR YOUR RIFLESCOPE

Your scope needs very little maintenance. Exterior metal surfaces should be kept clean. A light dusting with a slightly dampened soft cloth is enough in most cases.

Your new scope features windage and elevation turrets that are completely sealed against water intrusion. However, we recommend that you keep the windage and elevation caps on the turrets (*models with capped adjustments only*), except when making adjustments, to prevent dust and dirt from collecting in the turret area.

We also recommend that lens covers be kept in place when the scope is not being used. Lenses should be inspected regularly and kept clean at all times. Dust, dirt, and fingerprints that collect on the lens surfaces will severely degrade image quality, and if left unclean for long periods, the anti-reflection coating could be damaged. Although lens cleaning is not difficult, it does require care and some patience.

- Start with a lens brush or a small, soft bristle paintbrush. Gently whisk away loose dirt particles.
- Next, use an ear syringe or bulb aspirator (available in most drug stores) to blow remaining dirt or dust from lens surfaces.
- If further cleaning is needed, use a dry, soft lint-free cloth. Very gently wipe the lens, starting at the center using a circular motion, then working outward to the edge.
- If this has not corrected the problem repeat the process using condensation from your breath.

KEY ELEMENTS OF A SCOPE

There are four major elements of a scope:

- 1. Objective Lens:** This lens has three functions. First, it permits light to pass into the scope. Second, it determines resolution. Generally, larger lenses allow more light to enter the scope and resolve details better than smaller ones. Finally, it forms an image for the other lenses to magnify to a usable size. The image formed by this lens is upside down.
- 2. Erector System:** The erector system serves three functions. Its primary function is to erect the image (that is, flips the image right-side up) and align it to the reticle. During this process, primary magnification of the image takes place. These two functions are the result of lens action.

The third function is a mechanical one. The erector lenses are housed in a tube that is fixed at one end, while the other end of the tube is free to move and respond to dial adjustments. By moving the erector system, the point-of-aim of the scope is adjusted to match the point-of-impact of the bullet.

- 3. Reticle:** In simple terms, the aiming device around which the scope is built. This element replaces the iron sight system of non-scoped rifles.
- 4. Ocular or Eye Lens:** This element provides the secondary and final magnification of the image.

PARTS GUIDE

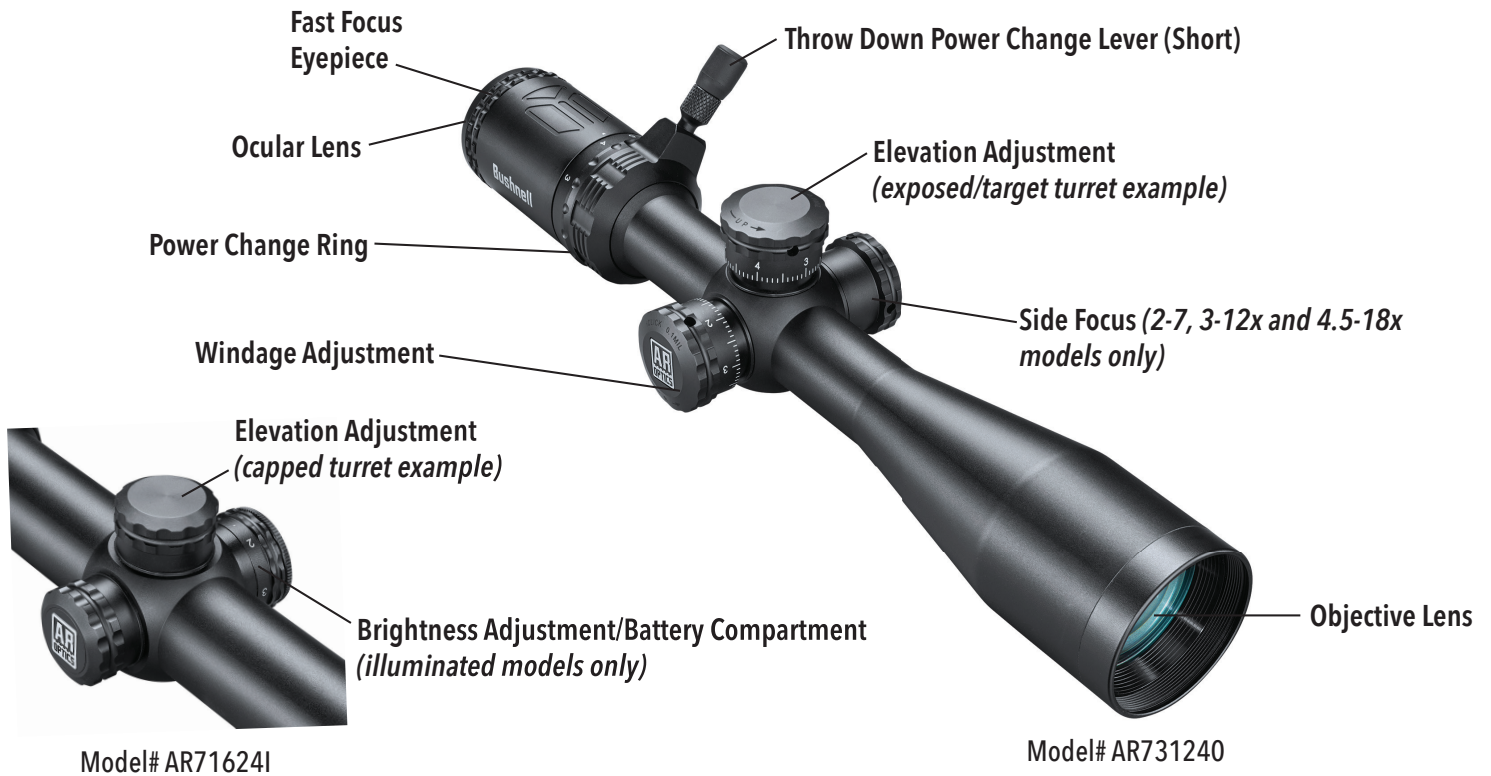

MOUNTING YOUR SCOPE

Your new scope, even with its technologically advanced design and features, will not perform at its best if not properly mounted. One of the most important contributing factors to the accuracy of your scope and rifle is the selection of the mount and the care with which mounting is done. Dependable mounts that attach your scope solidly to the rifle will reward you with dependability and consistent accuracy. You should take as much care in selecting a mounting system as you did in selecting your scope.

Remember, not all scopes are compatible with all mounts on all rifles. If there is any doubt in your mind, you should seek the advice of your local retailer or gunsmith.



WARNING: A RIFLESCOPE SHOULD NEVER BE USED AS A SUBSTITUTE FOR EITHER A BINOCULAR OR SPOTTING SCOPE. IT MAY RESULT IN YOU INADVERTENTLY POINTING THE GUN AT ANOTHER PERSON.

PRELIMINARY SCOPE ADJUSTMENTS

Before installing the scope, we recommend you set the focus of the eyepiece to fit your individual visual requirement. Refocusing the ocular distance will result in a sharper reticle focus, an improved optical image, and will help to avoid eye fatigue when using the scope over prolonged periods of time. To refocus, hold the scope about 3 to 4 inches from your eye and point at the open sky or other flatly lit area such as a monotone painted wall.

Quickly glance into the scope. If the reticle appears blurred at first glance, it is out of focus. Turn the eyepiece clockwise or counter clockwise several turns. Glance into the scope again to check the sharpness of the reticle. Remember to take quick glances, as the eye will compensate for slightly out of focus conditions with prolonged looks. If the reticle still appears blurred, turn the eyepiece another two or three turns. Repeat this procedure until the reticle is sharp and clearly defined.

Unless your eyes undergo a significant change over the years, you will not have to make this adjustment again.

VARIABLE POWER ADJUSTMENTS

To change magnification, fold the Throw Down PCL (Power Change Lever) out and use it to rotate the Power Selector Ring so the desired number on the power scale is aligned with the Index Dot (3x in the photos). For even more rapid power change operation, unscrew the top half



Throw Down PCL (Short)



Throw Down PCL (Long*)

*Short Lever pre-installed, Long Lever included in box

of the PCL (short lever) and replace it with the longer PCL (included). Lower powers provide a wider field of view. Higher powers should be reserved for precise long-range shots. Scopes with second focal plane reticles are calibrated for drop references at their highest power setting.

ATTACHING A MOUNT, RINGS AND SCOPE TO YOUR RIFLE



WARNING: BEFORE BEGINNING THE MOUNTING PROCEDURE, BE SURE THE ACTION IS OPEN, THE CLIP OR MAGAZINE IS REMOVED AND THE CHAMBER IS CLEAR. DO NOT ATTEMPT ANY WORK UNTIL YOUR FIREARM HAS BEEN CLEARED AND DETERMINED TO BE SAFE.



WARNING: IF THE SCOPE IS NOT MOUNTED FAR ENOUGH FORWARD, ITS REARWARD MOTION MAY INJURE THE SHOOTER WHEN THE RIFLE RECOILS.

In mounting your scope, we recommend that you DO NOT take short cuts as it may lead to damage to either the mounting system or to the scope. Each mounting system will have its own instructions to follow, and it is best to read the instructions first to be sure you understand them and have the necessary tools on hand.

We further recommend that you plan to go through the mounting procedure twice. The first time, to be sure everything fits together and functions properly. On the first run through, please keep the following in mind:

- Before attaching the base, clean the mounting holes in the receiver and the threads of the attaching screws with acetone or any good solvent to free them of oil or grease.
- If the mount manufacturer has recommended the use of a thread adhesive, do not use it on the first mounting trial. Once adhesive has set, it is difficult to demount if anything needs correction.
- Be sure the mounting screws do not protrude into the receiver or the barrel.
- When using dovetail mounts, do not use the scope as a lever when installing the scope. The initial resistance to turning may cause damage to the scope, and is not covered by the warranty. We recommend using a 1" wooden dowel or metal cylinder to seat the rings.
- Be sure the position of the scope does not interfere with the operation of the action.
- Be sure there is at least 1/8" of clearance between the edges of the rings and any protruding surfaces such as the turret housing (saddle), power selecting ring, and the flare of the objective bell. Also be sure there is at least 1/8" of clearance between the objective bell and the barrel.
- You should test position the scope for the proper eye relief. The scope rings should be left loose enough so that the scope will slide easily. Variable power scopes should be set at the highest magnification when performing this procedure. Mount the rifle and look through the scope in your normal shooting position.
- Test position the rifle for the proper cheek weld a number of times to ensure that your scope is positioned properly.
- When you are satisfied that everything is okay, demount and start again. This time, seat all screws firmly.

PARALLAX

You may have noticed that placing your eye at different positions behind the scope's eyepiece causes the reticle crosshairs to appear to move around to different points on your target. This is called "parallax error" (target and reticle are not in the same focal plane), and it becomes more noticeable (and more of a problem) at shorter distances and/or when the scope is set to higher powers. In most cases, parallax will not affect bullet point of impact enough to be of significant concern in large game hunting situations. AR Optics models with 12x or 18x high magnification provide an adjustment for parallax compensation (side focus knob), which works by moving an optical element until the target (based on its distance) appears in the same plane of focus as the reticle. All AR Optics scopes without user adjustable parallax compensation (fixed focus) are set at the factory to be parallax-free at 100 yards.

USING THE SIDE FOCUS (*Selected Models Only*)

Many AR Optics models with high magnification capability utilize a parallax compensation design with a movable lens back near the reticle, so the user can make an adjustment with a "side focus" knob placed opposite the windage turret, eliminating or reducing the aiming errors caused by parallax. **Be sure you have used the fast focus eyepiece to obtain a sharp image of the reticle for your eyesight first.** One way to set the side focus is to just line up the estimated distance to your target with the index dot. An alternative method is to look through the scope and turn the side focus knob until the target, at whatever range, is sharply focused. After setting the side focus, you can double check by moving your head around from side to side behind the eyepiece. The point of aim should not appear to shift if the side focus is correctly set.

PRELIMINARY SIGHTING-IN

You can save a significant amount of expense and frustration by pre-sighting the scope to the rifle before you take it to the range for zeroing.

There are two basic methods that can be used for pre-sighting your scope. Method one is to use a Bushnell® Bore Sighter (laser, magnetic or standard). The use of a Bore Sighter saves time and ammunition and is the system most often used by gunsmiths. The second method is traditional bore sighting:

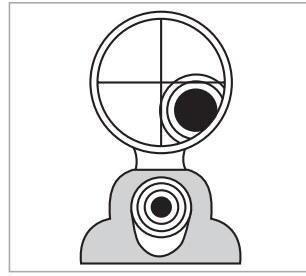

Fig. A
Reticle not in alignment

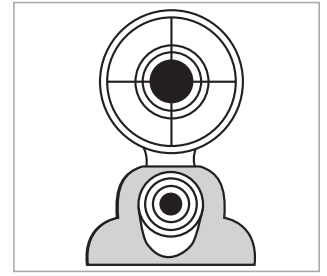

Fig. B
Reticle in alignment

BORE SIGHTING METHOD

1. Place a target at 25 to 50 yards.
2. Remove the bolt from the rifle.
3. Place the rifle on sandbags or a shooting rest.
4. Set the scope to its lowest magnification.
5. Peer through the bore from the receiver and adjust the position of the rifle to center the target bull's eye in the bore (*Fig. A*).
6. Without moving the rifle, look into the scope and note the position of the reticle on the target. On models with capped elevations and windage adjustments, remove the caps. Adjust the windage and elevation adjustments to center the reticle on the bull's eye (*Fig. B*).

FINAL SIGHTING-IN



WARNING: SINCE THIS PROCEDURE INVOLVES LIVE FIRE, IT SHOULD BE DONE AT AN APPROVED RANGE OR OTHER SAFE AREA. CHECK BORE FOR OBSTRUCTIONS. AN OBSTRUCTED BORE MAY CAUSE INJURY TO YOU AND OTHERS NEARBY. EYE AND EAR PROTECTION IS RECOMMENDED.

1. From a steady rest position, fire two or three rounds at a 100-yard target (*use 50 yards for 2-7x36 model with Drop-Zone 22LR reticle*). Note the impact of the bullet on the target and adjust the windage and elevation dials as needed.
2. To move the bullet impact, turn the windage and/or elevation adjustments in the direction on the dials that corresponds to where the impact point falls on the target (for example, if test shots are hitting low, adjust elevation "down"). The adjustments on your riflescope model are marked in MOA (minutes of arc), and the point of impact at 100 yards will change by 1/4 MOA for each click of the windage or elevation adjustment. One full revolution of the adjustment=12 MOA.
3. When the impact on the 100-yard target is satisfactory, switch to a target set at the desired distance for final zeroing. Set the magnification to the desired power on variable power models.

MODELS WITH ILLUMINATED RETICLES

Illuminated AR Optics scopes (*model # ends with "I"-see table on next page*) provide a brightness adjustment control on one side (instead of or combined with a side focus knob), numbered from 0 to 11 (*Fig. 1*). To increase the brightness, set the control to a higher number (opposite the white index dot). To turn off the illumination and when storing the scope, set the dial to "0". To replace the battery, remove the cap on the brightness adjustment control knob using a coin, and insert a CR2032 battery with the "+" mark facing up (*Fig. 2*).



Fig. 1



Fig. 2

FIRST AND SECOND FOCAL PLANE RETICLES

Some AR Optics riflescopes covered by this manual have their reticles located in the first focal plane ("FFP"). Therefore, the reticle will increase in size when the magnification is increased (and appear smaller at lower magnifications). This feature allows the continued use of the bullet drop/range system provided by the reticle, regardless of the power setting. Second focal plane ("SFP") reticles maintain a constant reticle size, but require the user to make measurements at a specific power, (typically the highest magnification setting) as the reticle remains the same size and will not account for different magnification levels.

ALTITUDE AND TEMPERATURE

Ballistic charts published by ammunition manufacturers are based upon standard sea level conditions. When sighting in, it is well to keep in mind that altitude and temperature affect trajectory. It is best to sight-in under the same conditions in which you will be hunting.

Technical Specifications

SKU/Model #	Mag x Obj. Diam.	Reticle	Focal Plane	Illumination	Tube Diameter	Adj. Range Elev/ Wind (MOA)	Travel per Revolution	Parallax Adjustment	Min. Parallax (Yards)	Eye Relief, Max Mag.	Field of View -Lo/ Hi Mag @ 100 Yds (Feet)	Length (inches)	Weight (oz)
AR71424	1-4x24	Drop-Zone 223	SFP	No	30 mm	120/140	6 Mil	Fixed	100	3.5 in	112-27	9.4	18
AR71424BI	1-4x24	BTR-300 Blackout	FFP	Yes	30 mm	120/140	6 Mil	Fixed	100	3.5 in	112-27	9.4	18
AR71424I	1-4x24	BTR-1	FFP	Yes	30 mm	120/140	6 Mil	Fixed	100	3.5 in	112-27	9.4	18
AR91424	1-4x24	BDC	SFP	No	30 mm	120/140	6 Mil	Fixed	100	3.5 in	112-27	9.4	18
AR91424BI	1-4x24	BTR-300 Blackout	FFP	Yes	30 mm	120/140	6 Mil	Fixed	100	3.5 in	112-27	9.4	18
AR91424I	1-4x24	BDC	FFP	Yes	30 mm	120/140	6 Mil	Fixed	100	3.5 in	112-27	9.4	18
AR71624I	1-6x24	BTR-1	SFP	Yes	30 mm	50/50	6 Mil	Fixed	100	3.6 in	100-16	10.2	16.5
AR71824I	1-8x24	BTR-1	SFP	Yes	30 mm	50/50	6 Mil	Fixed	100	3.6 in	100-16	10.2	16.5
AR92732	2-7x32	BDC	SFP	No	1 in	50/85	6 Mil	Fixed	100	3.5 in	44-12	11.3	18
AR72736	2-7x36	Drop-Zone 22LR	SFP	No	1 in	50/85	6 Mil	Side	10	3.5 in	44-12	11.3	18
AR731240	3-12x40	Drop-Zone 223	SFP	No	1 in	50/85	6 Mil	Side	10	3.5	29-7	12.0	19
AR931240	3-12x40	BDC	SFP	No	1 in	50/85	6 Mil	Side	10	3.5	29-7	12.0	19
AR73940	3-9x40	Drop-Zone 223	SFP	No	1 in	50/85	6 Mil	Fixed	10	3.5	29-11	12.0	19
AR93940	3-9x40	BDC	SFP	No	1 in	50/85	6 Mil	Fixed	10	3.5	29-11	12.0	19
AR93940B	3-9x40	Drop-Zone 223	SFP	No	1 in	50/85	6 Mil	Fixed	10	3.5	29-11	12.0	19
AR741840	4.5-18x40	Drop-Zone 223	SFP	No	1 in	50/80	6 Mil	Side	10	3.5	22-6	12.3	20
AR741840B	4.5-18x40	Drop-Zone 308	SFP	No	1 in	50/80	6 Mil	Side	10	3.5	22-6	12.3	20
AR741840C	4.5-18x40	Drop-Zone 6.5 Creedmor	SFP	No	1 in	50/80	6 Mil	Side	10	3.5	22-6	12.3	20
AR741840D	4.5-18x40	Drop-Zone 224 Valkyrie	SFP	No	1 in	50/80	6 Mil	Side	10	3.5	22-6	12.3	20
AR741840E	4.5-18x40	Wind Hold	SFP	No	1 in	50/80	6 Mil	Side	10	3.5	22-6	12.3	20
AR741840EI	4.5-18x40	Wind Hold	SFP	Yes	1 in	50/80	6 Mil	Side	10	3.5	22-6	12.3	20
AR945184	4.5-18x40	Drop-Zone 223	SFP	No	1 in	50/80	6 Mil	Side	10	3.5	22-6	12.3	20

THE DROP ZONE-22 RIMFIRE BALLISTIC RETICLE

Scopes with the DROP ZONE-22 Rimfire Reticle are designed to be sighted-in at 50 yds, with aiming points every 25 yds, out to 125 yds. This reticle is calibrated for use with .22 Long Rifle high velocity ammunition. AR Optics scopes with reticles in the second focal plane (refer to tech specs chart if not sure about your model) must also be turned to the highest magnification setting to use the reticle's drop point distance markings correctly for reference. For example, in the case of the 2-7x 32mm model, the power change ring must be set at 7x for the ballistic function to work correctly.

How To Use the Reticle:

1. Sight in at 50 yds on any magnification setting.
2. Determine distance to target. For the best accuracy in determining distance, utilize a Bushnell Laser Rangefinder (Prime, Nitro, Engage, etc.).
3. Set the scope's magnification to 7x (7 power).
4. Place the appropriate aiming point on the desired target. If the target was determined to be at 115 yds, hold directly between the 100 yd aiming point and the 125 yd aiming point.

DROP ZONE-22 RIMFIRE BALLISTIC RETICLE

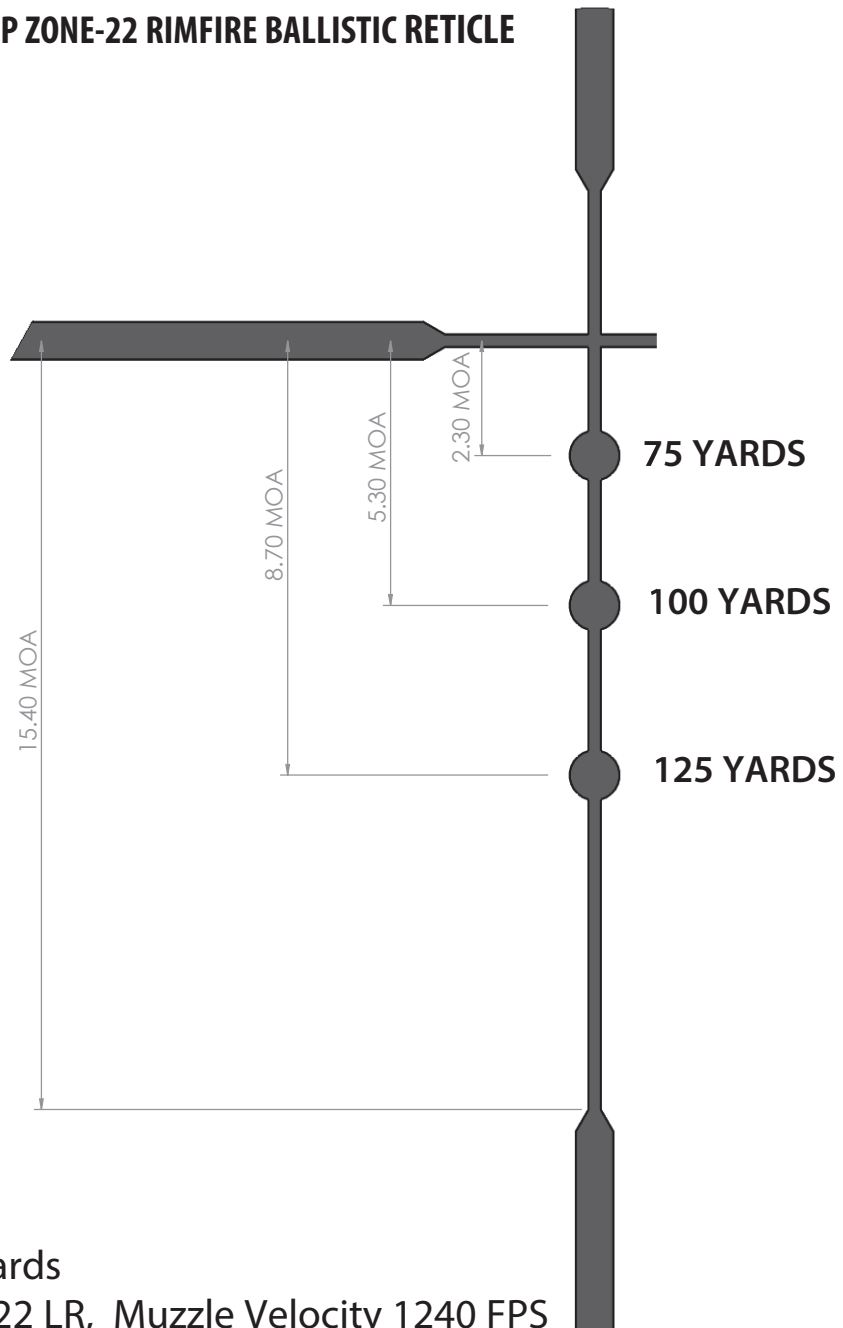

Calibration Reference

Zero Distance: 50 Yards

Ammo Load: 40 gr .22 LR, Muzzle Velocity 1240 FPS

THE DROP ZONE-223 BALLISTIC RETICLE

Scopes equipped with the DROP ZONE-223 ballistic reticle are designed to be sighted-in at 100 yds, and provide aiming points in the shape of a dot every 100 yds, out to 500 yds. In addition, the top of the reticle's bottom post (located below the 4th dot) represents a holdover point for a shot at 600 yds.

The Drop Zone 223 reticle is calibrated for use with 223 Rem/5.56 ammunition loaded with 55-62 grain bullets. AR Optics scopes with reticles in the second focal plane (refer to tech specs chart if not sure about your model) must also be turned to the highest magnification setting to use the reticle's drop point distance markings correctly for reference. For example, in the case of the 3-9x 40mm model, the power change ring must be set at 9 power. The 4.5-18x 40mm models should be set at 18 power.

How To Use the Reticle:

1. Sight in at 100 yds on any magnification setting.
2. Determine distance to target. For the best accuracy in determining distance, utilize a Bushnell Laser Rangefinder (Prime, Nitro, Engage, etc.).
3. Set the scope's magnification to its highest power.
4. Place the appropriate aiming point on the desired target. If the target was determined to be at 350 yds, hold directly between the 300 yd aiming point and the 400 yd aiming point.

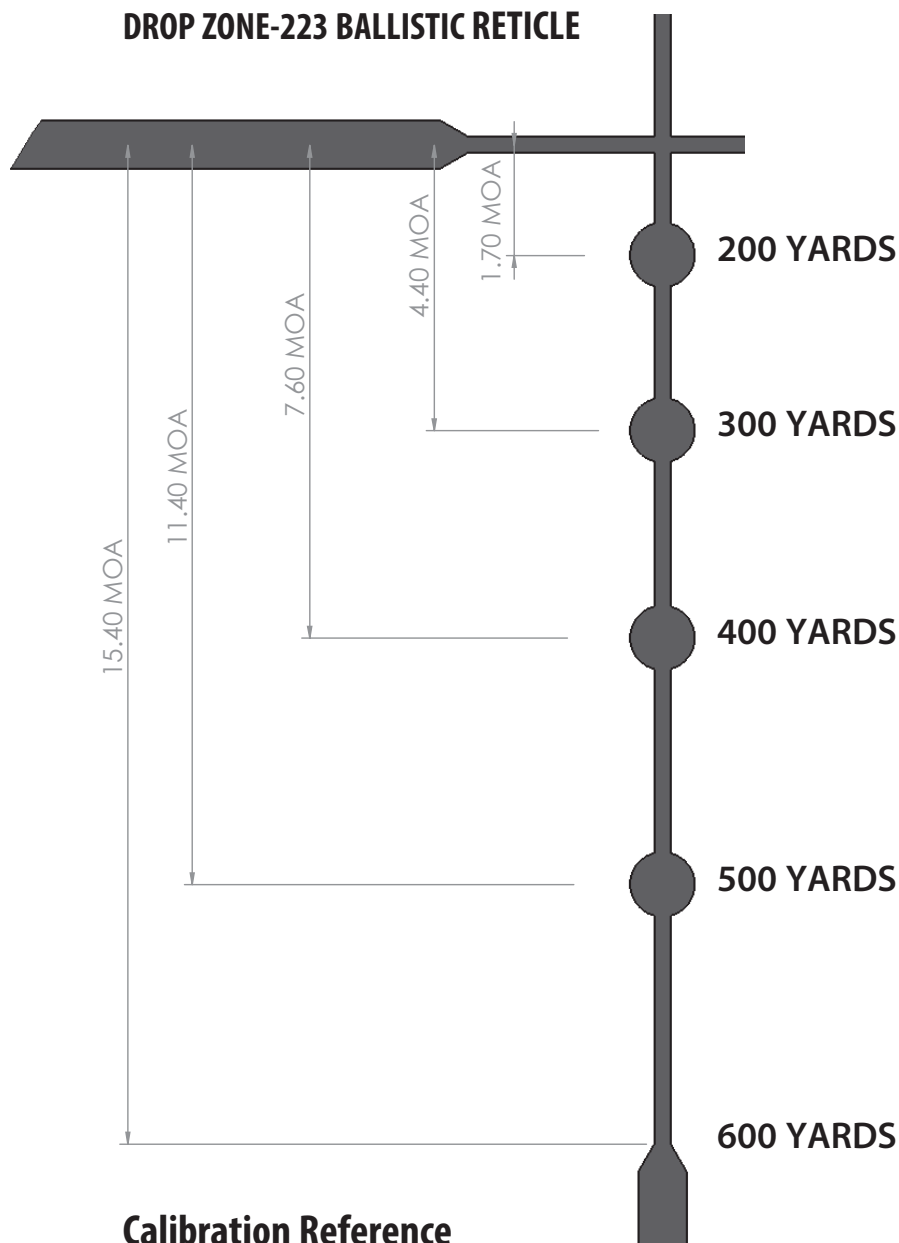

Calibration Reference

Zero Distance: 100 Yards

Ammo Load: 55-62 gr .223, Muzzle Velocity 2875

THE DROP ZONE-308 BALLISTIC RETICLE

Scopes equipped with the DROP ZONE-308 ballistic reticle are designed to be sighted-in at 100 yds, and provide aiming points in the shape of a dot every 100 yds, out to 500 yds. In addition, the top of the reticle's bottom post (located below the 4th dot) represents a holdover point for a shot at 600 yds.

The Drop Zone 308 reticle is calibrated for use with 308 Win/7.62 ammunition loaded with 168-175 grain bullets. AR Optics scopes with reticles in the second focal plane (refer to tech specs chart if not sure about your model) must also be turned to the highest magnification setting to use the reticle's drop point distance markings correctly for reference. For example, in the case of the 3-9x 40mm model, the power change ring must be set at 9 power. The 4.5-18x 40mm models should be set at 18 power.

How To Use the Reticle:

1. Sight in at 100 yds on any magnification setting.
2. Determine distance to target. For the best accuracy in determining distance, utilize a Bushnell Laser Rangefinder (Prime, Nitro, Engage, etc.).
3. Set the scope's magnification to its highest power.
4. Place the appropriate aiming point on the desired target. If the target was determined to be at 350 yds, hold directly between the 300 yd aiming point and the 400 yd aiming point.

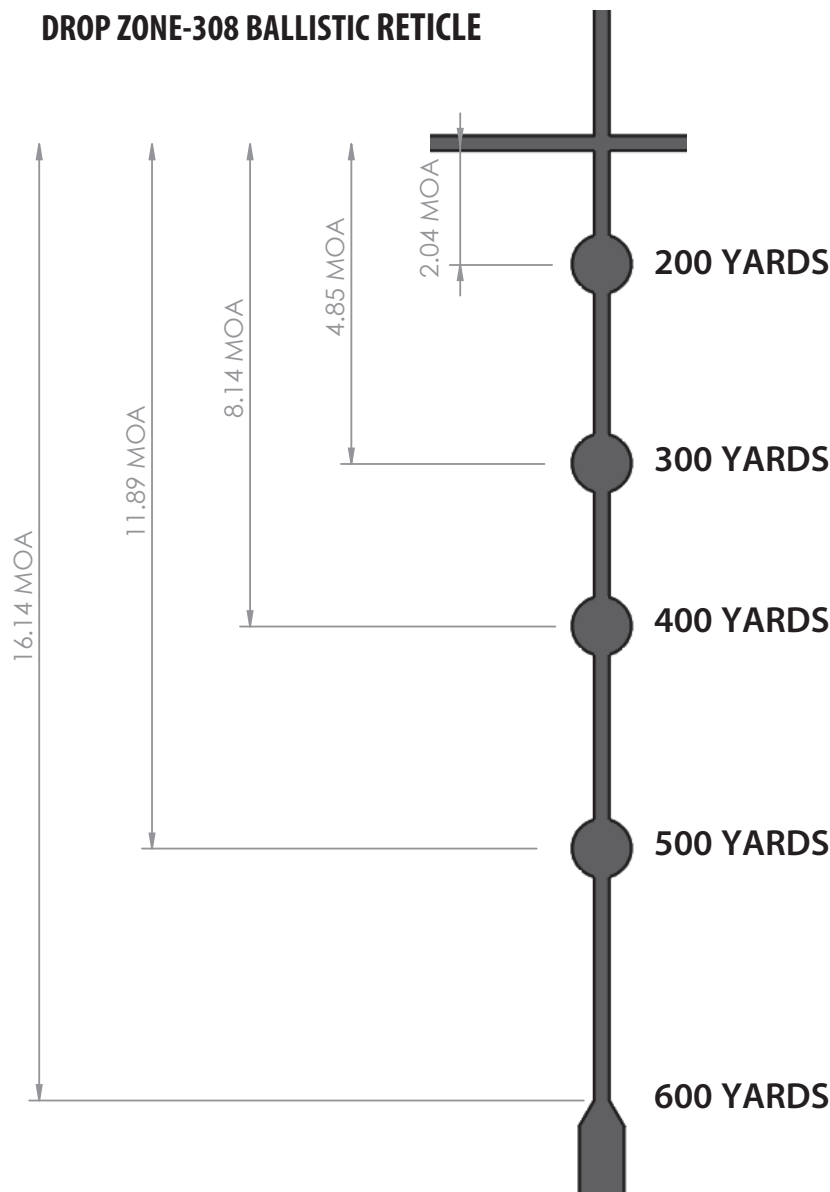

Calibration Reference

Zero Distance: 100 Yards

Ammo Load: 168-175 gr .308, Muzzle Velocity 2600

THE BTR-1 TACTICAL RETICLE

Scopes with the BTR-1 (Bushnell Tactical Reticle) are designed to be sighted-in at 100 yds, with aiming points every 100 yds, out to 500 yds. This reticle is calibrated for use with 223 Rem/5.56 ammunition loaded with 55-62 grain bullets. AR Optics scopes with reticles in the second focal plane (refer to tech specs chart if not sure about your model) must also be turned to the highest magnification setting to use the reticle's drop point distance markings correctly for reference.

How To Use the Reticle:

1. Sight in at 100 yds on any magnification setting.
2. Determine distance to target. For the best accuracy in determining distance, utilize a Bushnell Laser Rangefinder (Prime, Nitro, Engage, etc.).
3. Place the appropriate aiming point on the desired target. If the target was determined to be at 350 yds, hold directly between the 300 yd aiming point and the 400 yd aiming point.

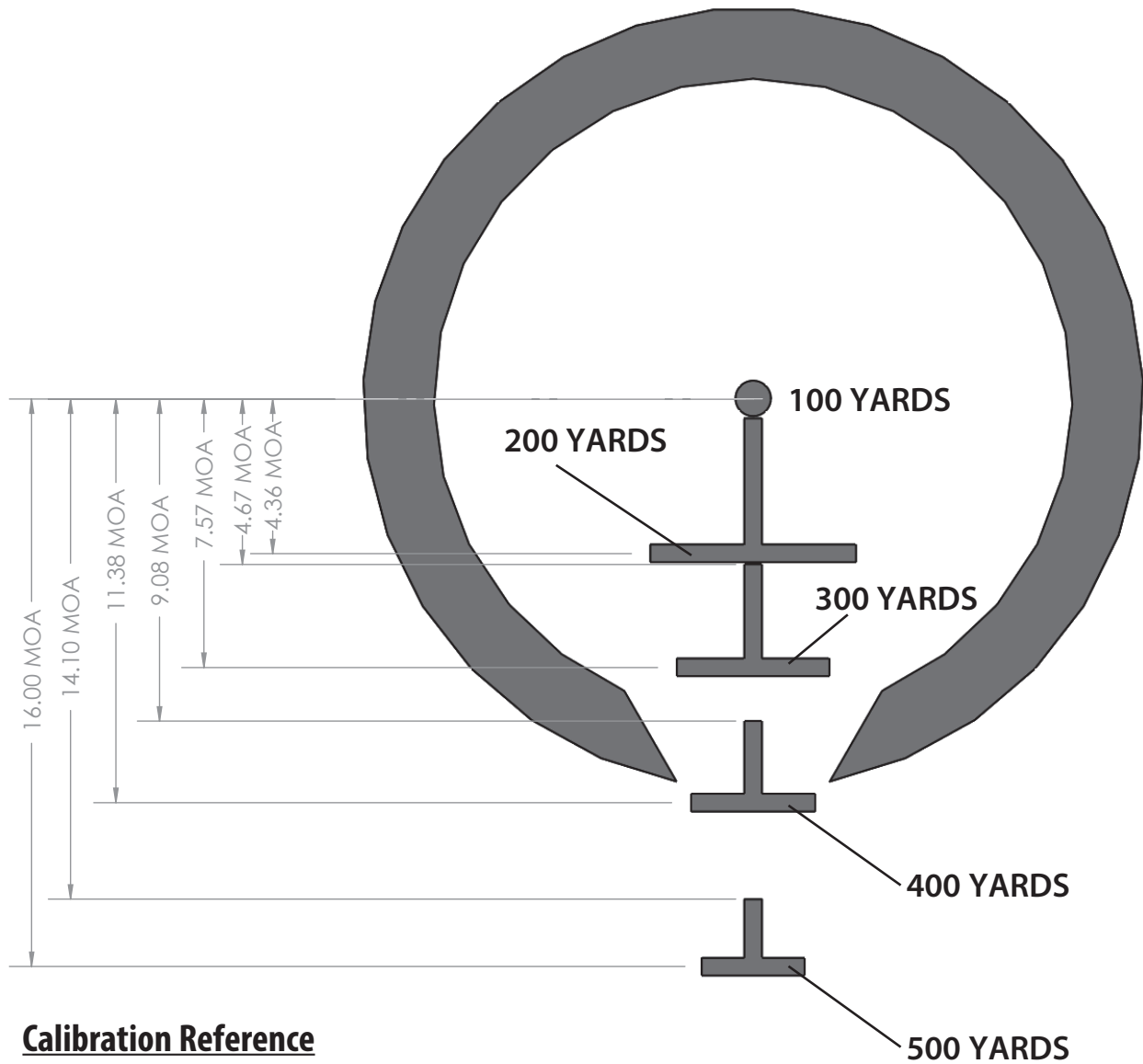

Calibration Reference

Zero Distance: 100 Yards

Ammo Load: 55-62 gr .223, Muzzle Velocity 2875

THE DROP ZONE 6.5 CREEDMOOR RETICLE

The Drop Zone 6.5 reticle is ideal for use with 6.5 Creedmoor centerfire cartridges in target shooting and hunting applications. After you initially sight in and establish a point of aim at 100 yards using the center of the reticle, bullet drop compensation will be indicated by the dots below it for distances from 200 to 500 yards (the bottom of the crosshair can be used for 600 yards).

The image below provides a detailed look at the Drop Zone 6.5 reticle.

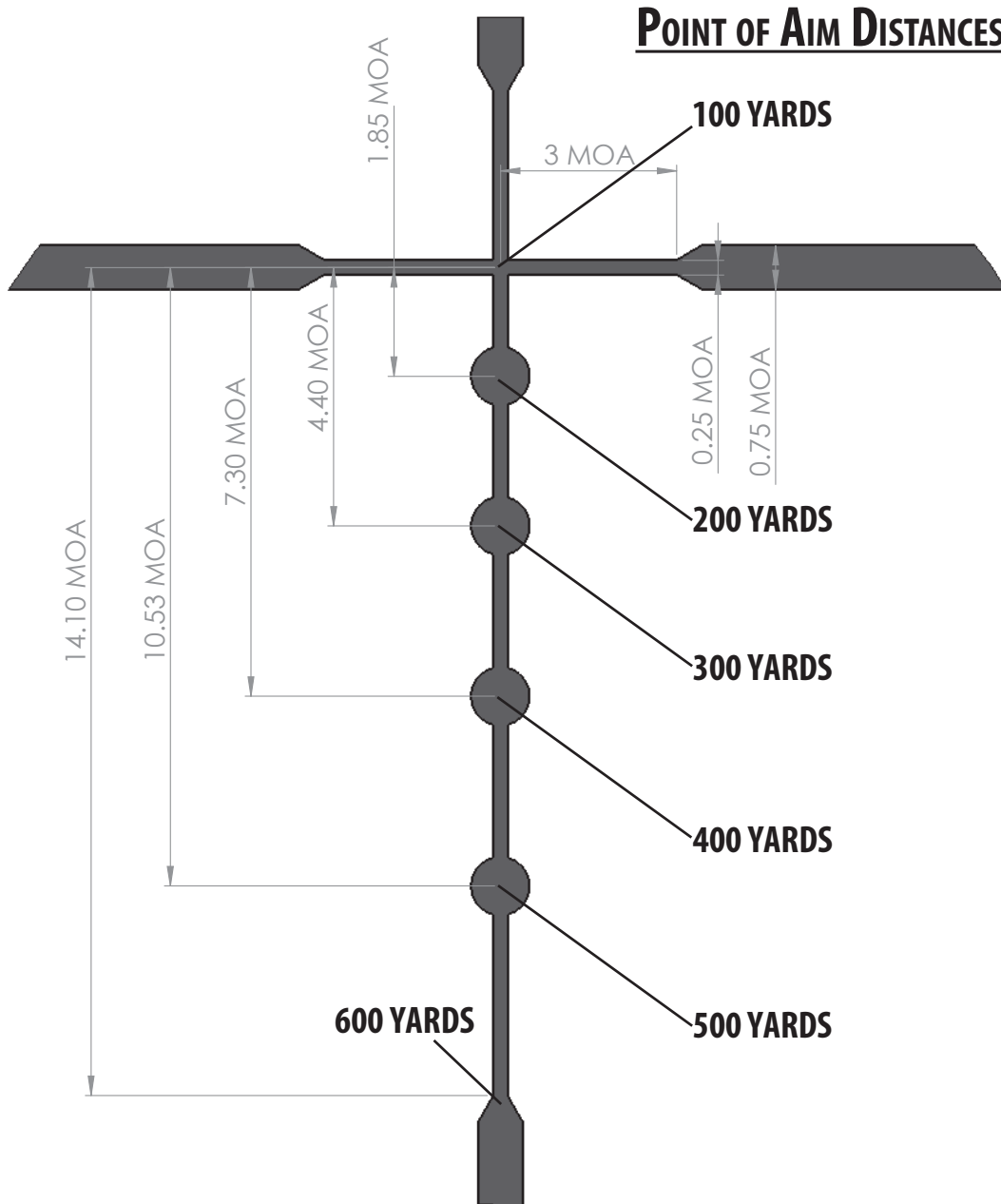

Calibration Reference

Zero Distance: 100 Yards

Ammo Load: 140 gr Open Tip Match 6.5 Creedmoor, Muzzle Velocity 2700 FPS

THE BTR-300 BLACKOUT RETICLE

The BTR-300 reticle can be used with both subsonic and supersonic velocity loads. When using subsonic loads, it should be sighted-in at 50 yards, and provides aiming points at 100 and 125 yards. For supersonic loads, sight in your scope at 100 yards. The two lower dots can be used for 235 and 300 yard distances.

The image below provides a detailed look at the BTR-300 reticle.

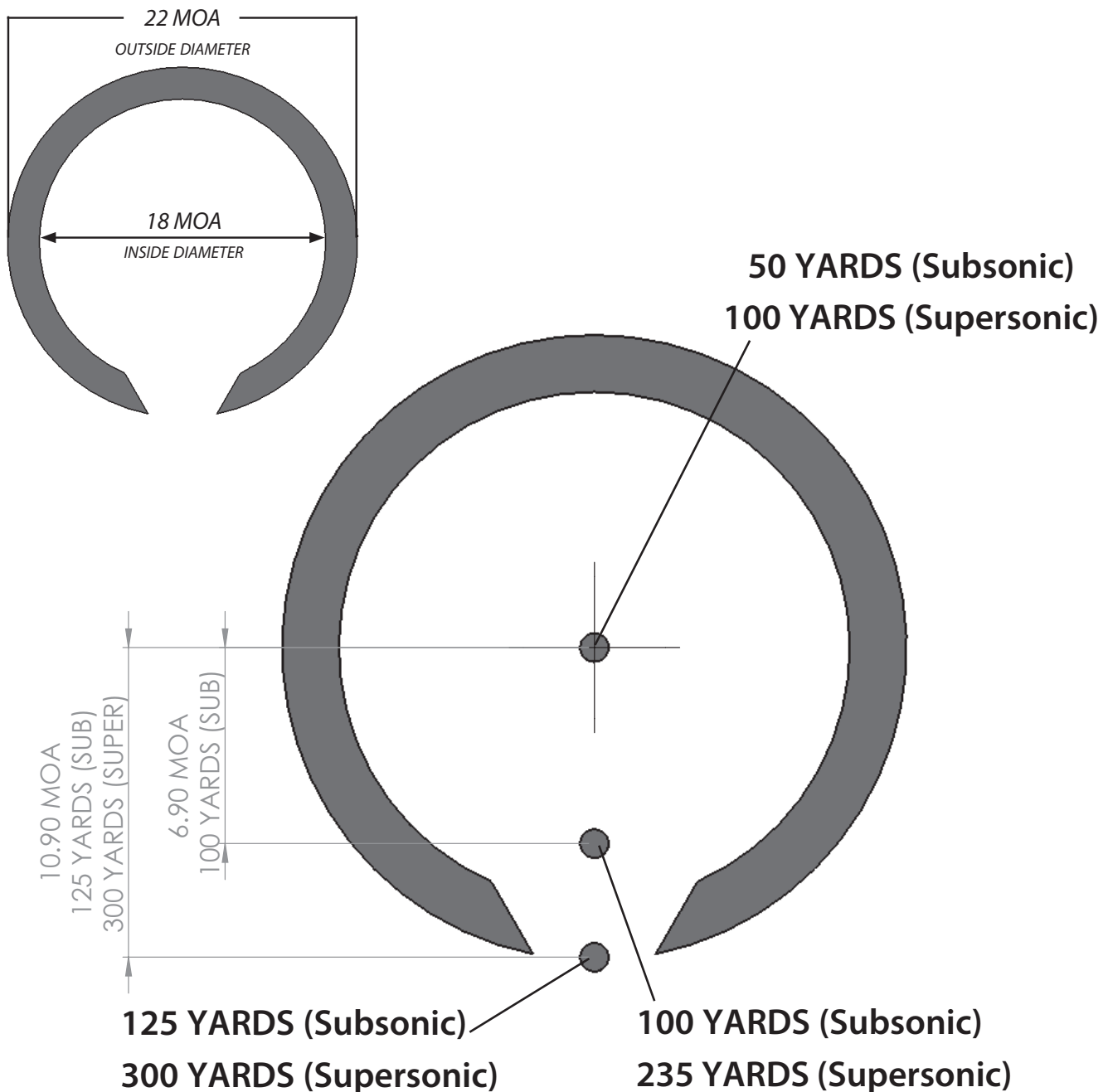

Calibration Reference

Zero Distance: 50 Yards (Subsonic Loads) or 100 Yards (Supersonic Loads)

Ammo Load: 150 gr Subsonic 300 Blk, Muzzle Velocity 1900 FPS

220 gr Supersonic 300 Blk, Muzzle Velocity 1000 FPS

THE WINDHOLD RETICLE

The Windhold reticle is a special version of Bushnell's traditional "Multi-X" reticle, available in two 4.5-18x40 models. Hash lines on the horizontal axis indicate 1.0 MIL (MilRad) of windage holdover, with dots marking .5 MIL increments. The hash line on the lower half of the vertical crosshair is 1.0 MIL from the center of the reticle.

The image below provides a detailed look at the Windhold reticle, both with and without illumination.

Non-illuminated version

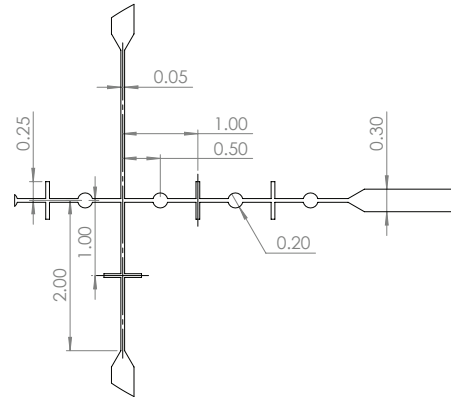
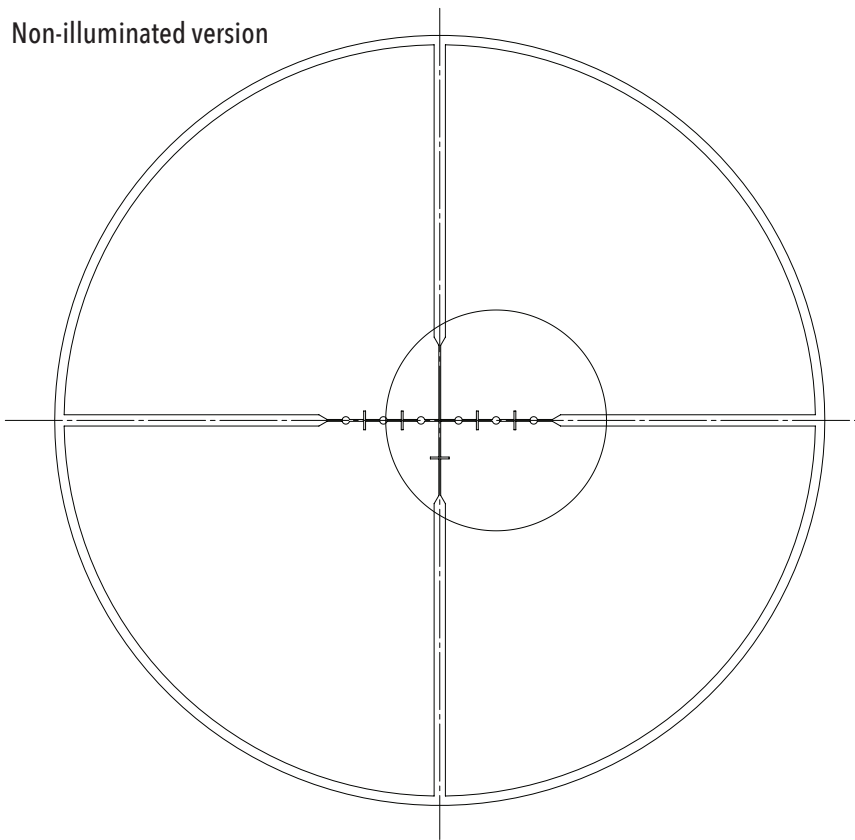

Illuminated version

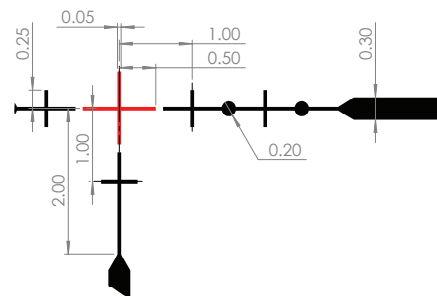
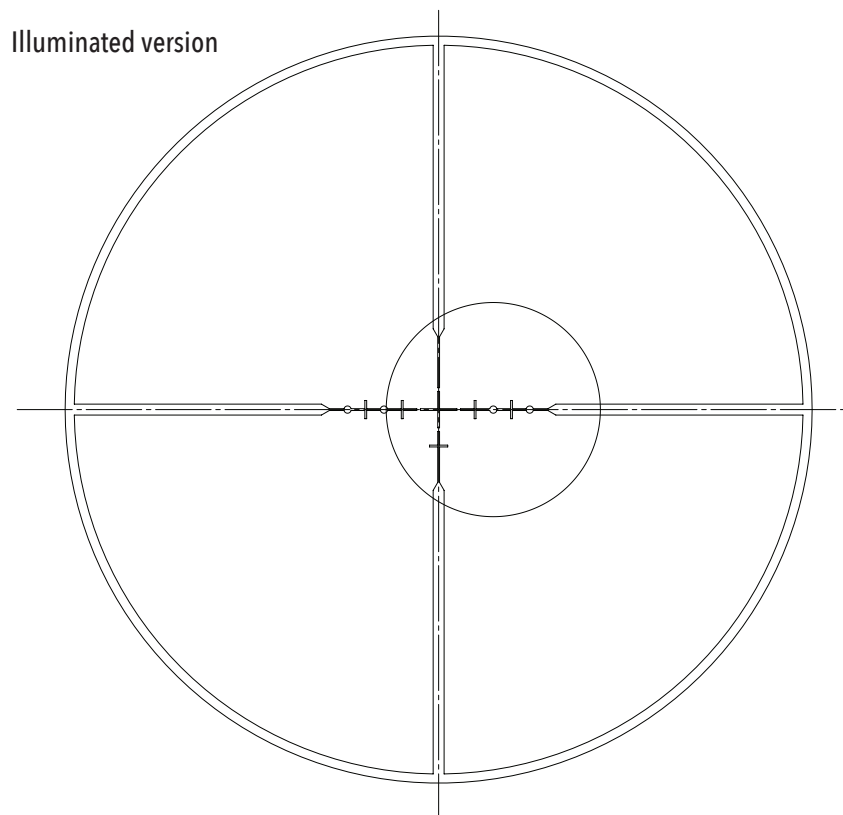

Special Instructions for Model# AR741840E / AR741840EI (4.5-18x40 w/interchangeable elevation turret knobs)

Model# AR741840E and AR741840EI (illuminated version) include these four additional BDC elevation turret knobs:

- (1) 223 Rem
- (1) 308 Win
- (1) 6.5 Creedmoor
- (1) 224 Valkyrie



A standard 0.1 Mil click turret (6 Mils per rev) is pre-installed.

To switch to any of the optional elevation turrets:

1. Before starting, sighting-in the scope with the pre-installed standard turret set to the "0" position is recommended (*Fig. A*).
2. Using the provided tool, loosen the three hex bolts located around the top rim of the standard turret (*Fig. A, arrows*).
3. Remove the standard turret, lifting it straight up. The brass elevation adjustment post is exposed (*Fig B*). Set the standard turret aside in a safe place.
4. Replace the standard turret with the one that matches your load type (*see tables on next page*) and press it down into position onto the brass post, with the 100 yard mark on the turret lined up with the index mark on the scope (*Fig C*).
5. Secure the new turret in place by tightening the three hex bolts with the provided tool (*Fig C, arrow*).
6. Sight-in and zero the turret knob (at 100 yds), loosening the hex bolts and rotating the turret knob as needed for proper calibration at the 100 mark, then retightening the hex bolts.

Standard .1 Mil Turret Reference

1. 3.4377 MOA per 1 mil
2. At 100 yards distance
 - 1 mil = 3.599 in
 - 0.1 mil = 0.3599 in \approx 0.36 in
 - 1 moa = 1.047 in
 - 1/4 moa = 0.262 in
3. At 100m distance
 - 1 mil = 10 cm
 - 0.1 mil = 1 cm

Fig. A



Fig. B



Fig. C



Ballistic Reference Tables for Model# AR741840E / AR741840EI Elevation Turrets

223 REMINGTON

Zero Range: 100 yards
 Bullet Caliber: .223 Rem
 Bullet Type/Grain: 55 gr FMJBT
 Ballistic Coefficient (G1): 0.269
 Muzzle Velocity: 2875 fps

RANGE	HOLDOVER		
	(yds)	(in)	(MOA)
100	0	0	0
200	-2.74	1.31	0.38
250	-6.06	2.31	0.67
300	-10.92	3.47	1.01
350	-17.54	4.78	1.39
400	-26.18	6.25	1.82
450	-37.16	7.88	2.29
500	-50.82	9.7	2.82
550	-67.62	11.74	3.41
600	-88.05	14.01	4.08
650	-112.71	16.56	4.82
700	-142.26	19.41	5.64

224 VALKYRIE

Zero Range: 100 yards
 Bullet Caliber: .224 Valk
 Bullet Type/Grain: 90 gr SMK, BTHP
 Ballistic Coefficient (G1): 0.563
 Muzzle Velocity: 2700 fps

RANGE	HOLDOVER		
	(yds)	(in)	(MOA)
100	0.01	-0.01	0
200	-3.88	1.85	0.54
250	-8.06	3.08	0.9
300	-13.87	4.41	1.28
350	-21.4	5.84	1.7
400	-30.79	7.35	2.14
450	-42.14	8.94	2.6
500	-55.61	10.62	3.09
550	-71.33	12.38	3.6
600	-89.48	14.24	4.14
650	-110.21	16.19	4.71
700	-133.73	18.24	5.31

308 WINCHESTER

Zero Range: 100 yards
 Bullet Caliber: .308 Win
 Bullet Type/Grain: 150 gr FMJBT
 Ballistic Coefficient (G1): 0.408
 Muzzle Velocity: 2820 fps

RANGE	HOLDOVER		
	(yds)	(in)	(MOA)
100	0.01	-0.01	0
200	-3.66	1.75	0.51
250	-7.72	2.95	0.86
300	-13.46	4.28	1.25
350	-21.01	5.73	1.67
400	-30.57	7.3	2.12
450	-42.32	8.98	2.61
500	-56.48	10.78	3.14
550	-73.29	12.72	3.7
600	-93.03	14.8	4.31
650	-116	17.04	4.96
700	-142.54	19.44	5.66

6.5 CREEDMOOR

Zero Range: 100 yards
 Bullet Caliber: 6.5 Creedmoor
 Bullet Type/Grain: 130 gr AR Hybrid
 Ballistic Coefficient (G1): 0.56
 Muzzle Velocity: 2700 fps

RANGE	HOLDOVER		
	(yds)	(in)	(MOA)
100	-0.01	0	0
200	-3.26	1.55	0.45
250	-6.85	2.62	0.76
300	-11.86	3.77	1.1
350	-18.39	5.02	1.46
400	-26.53	6.33	1.84
450	-36.39	7.72	2.25
500	-48.09	9.18	2.67
550	-61.75	10.72	3.12
600	-77.51	12.33	3.59
650	-95.52	14.03	4.08
700	-115.93	15.81	4.6
750	-138.93	17.69	5.14
800	-164.69	19.66	5.72



BUSHNELL IRONCLAD WARRANTY

Products manufactured on or after April 2017 are covered by the Bushnell Ironclad Warranty. The Ironclad Warranty is a full lifetime warranty that covers the lifetime of this Product. Each Product has a defined lifetime; lifetimes can range from 1 to 30 years. This Product's lifetime can be found at the website listed below and/or on the Bushnell webpage specific to this Product.

We warrant that this Product is free from defects in materials and workmanship and will meet all represented performance standards for the lifetime of this Product. If this Product isn't working properly due to a covered defect, we will, at our option, either repair or replace it and ship it back to you at no charge. This warranty is fully transferable and does not require a receipt, warranty card, or product registration. This warranty does not cover the following: electronic components; batteries; cosmetic damage; damage caused by failing to properly maintain the product; loss; theft; damage as a result of unauthorized repair, modification, or disassembly; intentional damage, misuse, or abuse; and ordinary wear and tear. This Warranty will be void if the date stamp or other serialization codes have been removed from the Product.

To view the full warranty and find details on how to request service under the warranty, go to our website at www.bushnell.com/warranty. Alternatively, you can request a copy of the warranty by calling us at 1-800-423-3537 or writing to us at one of the following addresses:

IN U.S.A. Send To:

Bushnell Outdoor Products
Attn.: Repairs
9200 Cody
Overland Park, Kansas 66214

IN CANADA Send To:

Bushnell Outdoor Products
Attn.: Repairs
140 Great Gulf Drive, Unit B
Vaughan, Ontario L4K 5W1

For products purchased outside the United States or Canada please contact your local dealer for applicable warranty information.

This warranty gives you specific legal rights.
You may have other rights which vary from country to country.

©2019 Bushnell Outdoor Products

DO YOU NEED TO SEND YOUR SCOPE TO US?

Before returning your scope for service, you should check the following points to make sure the problem is with the scope:

- Check the mounting system and rings for looseness or misalignment.
- Check to be sure the barrel and action are properly bedded and all receiver screws are tight.
- Check to be sure the mounting system allows sufficient clearance between the objective bell and the barrel.
- Check to be sure you are using the same type and weight ammunition that you used for sighting-in.

Bushnell®

©2019 Bushnell Outdoor Products
Bushnell,™, ®, denote trademarks of Bushnell Outdoor Products
www.bushnell.com

9200 Cody, Overland Park, KS 66214