

Bushnell®



INSTRUCTION MANUAL

MODEL #: 181561
LIT. #: 98-1532/05-13

PARTS DIAGRAM

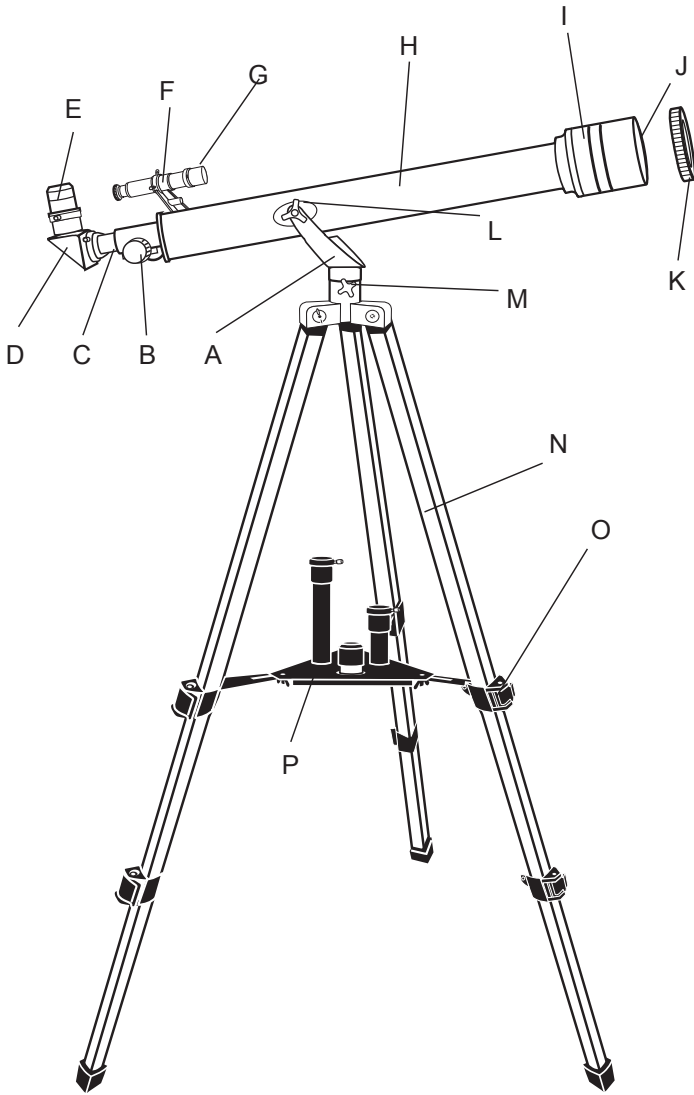

NOTE: Actual product may have improvements that are not shown in this diagram

- | | | |
|------------------------|--|---------------------------------|
| A. Yoke Mount | I. Sun Shade | O. Tripod Leg
Adjusting Knob |
| B. Focus Knob | J. Objective Lens
(not shown) | P. Accessory Tray |
| C. Focus Tube | K. Dust Cap (remove before
viewing) | |
| D. Diagonal | L. Yoke Locking Knob | |
| E. Eyepiece | M. Azimuth Lock | |
| F. Finderscope Bracket | N. Tripod Leg | |
| G. Finderscope | | |
| H. Telescope Main Body | | |

ASSEMBLY DIAGRAMS

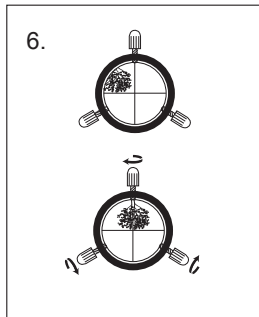
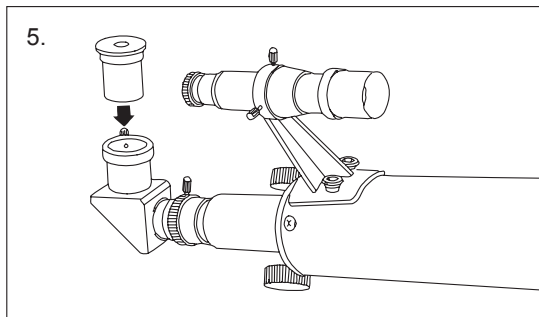
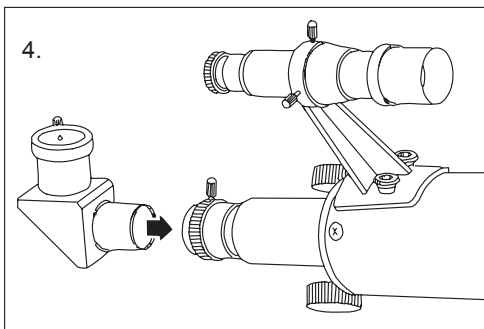
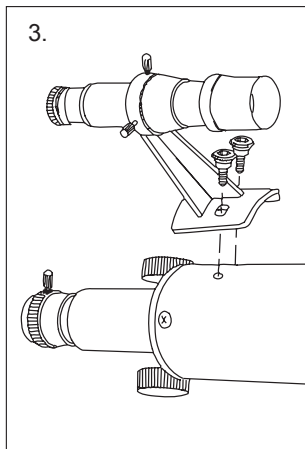

TELESCOPE ASSEMBLY INSTRUCTIONS

1. Your telescope has adjustable (telescoping) legs (*Fig. 1*).
2. Stand tripod and expand legs. Loosen the three leg locks. Grab tripod head and lift. Extend the tripod legs to the desired height (at equal lengths) and tighten the knobs on each leg to hold it in position (*Fig. 1*).
3. Attach the accessory tray (**P**) to the center leg braces on the tripod legs (*Fig 2*) and insert accessory tray and bolt through center of tray into braces and tighten bolt.
4. Remove telescope main body from the box. Attach telescope main body (**H**) by aligning the hole in the telescope saddle with that in the yoke. Screw yoke locking knobs (**L**) through both holes and tighten the knob.
5. Remove the finderscope (**G**) with finderscope bracket (**F**) attached from the box. Remove the two knurled thumbscrews from the telescope main body. Position the finderscope bracket on the telescope main body so that the holes in the base of the bracket line up with the exposed holes in the telescope main body. Replace the two-knurled thumbscrews and tighten securely (*Fig. 3*).
6. Insert diagonal (**D**) into the focus tube (**C**). Secure by tightening small retaining screw on the focus tube (*Fig. 4*).
7. Insert eyepiece (**E**) into diagonal (**D**). Secure by tightening small retaining screw (*Fig.5*).

NOTE: In all astronomical telescopes, the image appears upside down. With the use of the diagonal the image appears erect but with a left to right inversion (mirror like). To use the telescope for terrestrial view and to correct the mirrored image, insert the erecting eyepiece in between the diagonal and the eyepiece. We recommend the use of the low magnification eyepiece when the telescope is used for terrestrial viewing. Only refractor telescopes come with erector eyepieces. Reflectors (mirrors) are used mainly for astronomical purposes.

The telescope is now fully assembled and ready for use.

8. To use the Barlow, insert Barlow between the diagonal and the eyepiece. Secure by tightening small retaining screw. Insert eyepiece into open end of Barlow and secure.



CAUTION! Viewing the sun can cause permanent eye damage.
Do not view the sun with this telescope or even with the naked eye.



TO USE THE FINDERSCOPE

The finderscope is a small low-powered and wide field of view telescope mounted alongside the main telescope and is used to search for the target and aim the main telescope at it. But before you can use the finderscope, you will need to line it up with the telescope. This procedure will become easier with practice.

1. Install the lowest power eyepiece (25mm) into the eyepiece tube. Pick out an easily recognized, unmoving object no closer than a thousand yards away. Aim your telescope toward your object until its image is centered in the eyepiece. Lock all the knobs on the mount so the telescope will not move.
2. Look through the finderscope. If the object you lined up in the telescope is not visible, loosen the adjustment screws and move the finderscope around until you see it. Once it gets within range, tighten the adjustment screws while centering the object in the scope. You will note that the image will shift toward the screw you are tightening (*Fig. 6*).
3. Adjust screws to center object on the finderscope cross hairs. Recheck your telescope to make certain it is still on target. If it moved, realign it and adjust your finderscope. If it hasn't, you're all set. Your finderscope is now operational.

FINDING OBJECTS

1. Loosen the altitude locks on the sides of the telescope tube and the silver azimuth lock on the base of the altazimuth mount, then move the telescope in the desired direction.
2. Look through the finderscope and pan the telescope until the object appears in the field of view. Once it's in the field of view, tighten the altitude and azimuth locks.

FOCUSING

1. Once you have found an object in the telescope, turn the focus knob until the image is sharp.
2. To focus on an object that is nearer than your current target, turn the focusing knob toward the eyepiece (i.e., so that the focus tube moves away from the front of the telescope). For more distant objects, turn the focus knob in the opposite direction.
3. To achieve a truly sharp focus, never look through glass windows or across objects that produce heat waves, such as asphalt parking lots.

IMAGE ORIENTATION

1. When observing with a diagonal, the image will be right side up but reversed from left to right.
2. When observing straight through, with the eyepiece inserted directly into the telescope, the image will be inverted. Also, the image in the finderscope will be inverted.

MAGNIFICATION

1. The magnification (or power) of a telescope varies depending upon the focal length of the eyepiece being used and the focal length of the telescope.
2. To calculate magnification, use the following formula, in which FL = focal length:

$$\text{Magnification} = \frac{\text{FL (telescope) in mm}}{\text{FL (eyepiece)}}$$

TECHNICAL SPECIFICATIONS	
Objective Diameter:	50mm
Focal Length:	600mm
Eyepieces:	H25mm (Low Power) H12.5mm (Medium Power) SR4mm (High Power)
Erecting Eyepiece:	1.5x
Barlow:	2x
Maximum Magnification:	300x *
Accessories:	Diagonal, Finderscope, moon filter

* NOTE: Magnification is calculated magnification (4mm eyepiece+Barlow).
Low power is recommended for most viewing conditions.

EYE LENS CHART & THEORETICAL POWER LIMITS	
SR 4mm Eye Lens Power:	150x
H 12.5mm Eye Lens Power:	48x
H 25mm Eye Lens Power:	24x

WARRANTY / REPAIR

LIFETIME LIMITED WARRANTY

Your Bushnell® telescope is warranted to be free of defects in materials and workmanship for the lifetime of the original owner. The Lifetime Limited Warranty is an expression of our confidence in the materials and mechanical workmanship of our products and is your assurance of a lifetime of dependable service.

If your telescope contains electrical components, these components are warranted to be free of defects in materials and workmanship for two years after the date of purchase.

In the event of a defect under this warranty, we will, at our option, repair or replace the product, provided that you return the product postage prepaid. This warranty does not cover damages caused by misuse, improper handling, installation, or maintenance provided by someone other than a Bushnell Authorized Service Department.

Any return made under this warranty must be accompanied by the items listed below:

1. A check/money order in the amount of \$15.00 to cover the cost of postage and handling
2. Name and address for product return
3. An explanation of the defect
4. Proof of Date Purchased
5. Product should be well packed in a sturdy outside shipping carton, to prevent damage in transit, with return postage prepaid to the address listed below:

IN U.S.A. Send To:

Bushnell Outdoor Products
Attn.: Repairs
9200 Cody
Overland Park, Kansas 66214

IN CANADA Send To:

Bushnell Outdoor Products
Attn.: Repairs
25A East Pearce Street, Unit 1
Richmond Hill, Ontario L4B 2M9

For products purchased outside the United States or Canada please contact your local dealer for applicable warranty information. In Europe you may also contact Bushnell at:

Bushnell Germany GmbH
European Service Centre
Mathias-Brüggen-Str. 80
D-50827 Köln
GERMANY
Tel: +49 221 995568-0
Fax: +49 221 995568-20

This warranty gives you specific legal rights.
You may have other rights which vary from country to country.
©2013 Bushnell Outdoor Products

Bushnell®

For further questions or additional information please contact:

**Bushnell Outdoor Products
9200 Cody, Overland Park, Kansas 66214
(800) 423-3537 • www.bushnell.com**